



Very Well Connected™

INSTALLATION INSTRUCTIONS

Product

7160-0610 - Single Light Bracket
7160-0611 - Double Light Bracket

Revision

C

Form

INST-672

Printing Spec: PS-001

The following instruction sheet is for the products listed above. These products allow mounting capabilities for lighting.

- Using four 3/8" carriage bolts, attach the mounting plate and back plate to one of the bars on the overhead guard. Two bolt above and two bolts below.
- Attach the light to either the hole on the single light bracket or the slots on the double light bracket.

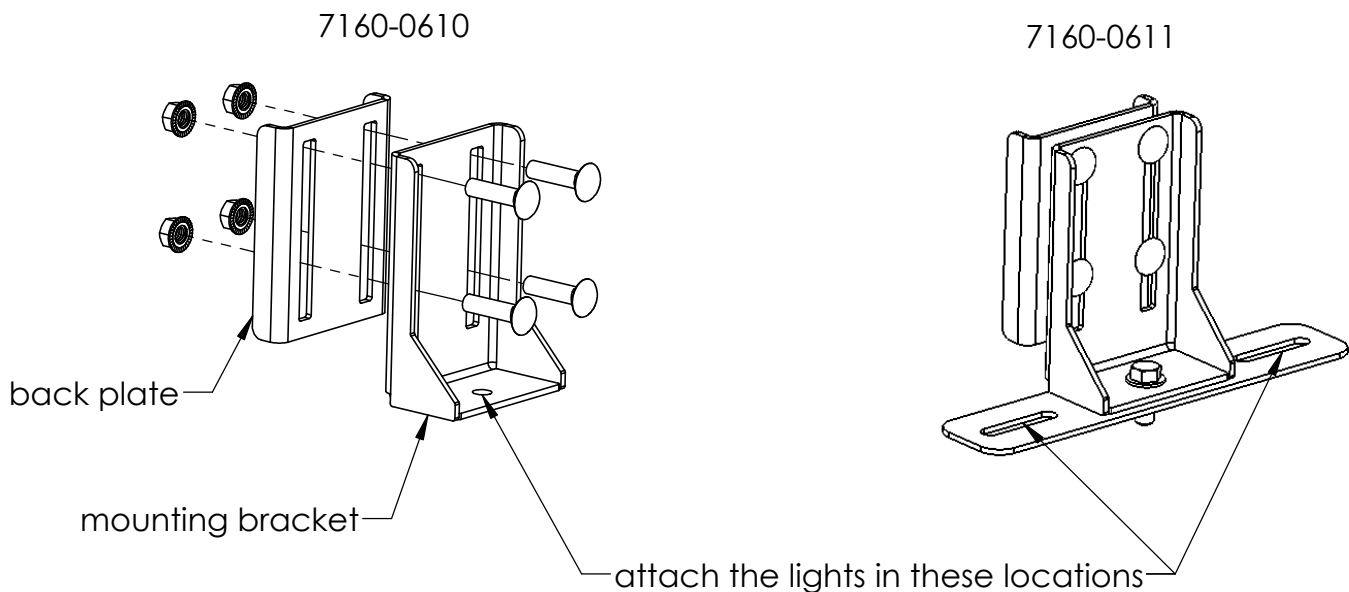

Product Mounting Disclaimer

Gamber-Johnson is not liable under any theory of contract or tort law for any loss, damage, personal injury, special, incidental or consequential damages for personal injury or other damage of any nature arising directly or indirectly as a result of the improper installation or use of its products in vehicle or any other application. In order to safely install and use Gamber-Johnson products full consideration of vehicle occupants, vehicle systems (i.e., the location of fuel lines, brakes lines, electrical, drive train or other systems), air-bags and other safety equipment is required. Gamber-Johnson specifically disclaims any responsibility for the improper use or installation of its products not consistent with the original vehicle manufactures specifications and recommendations, Gamber-Johnson product instruction sheets, or workmanship standards as endorsed through the Gamber-Johnson Certified Installer Program.

© copyright 2019 Gamber-Johnson, LLC

If you need assistance or have questions, call Gamber-Johnson at 1-800-456-6868

1 of 1