



# INSTALLATION INSTRUCTIONS

<b><u>Product</u></b> 7160-0817 PRINTER MOUNT, ZEBRA QLN420	<b><u>Revision</u></b> REV. B	<b><u>Form</u></b> INST-713  <b>Printing Spec:</b>
---	----------------------------------	---

The Zebra QLN420 printer bracket is designed to be mounted to various Gamber-Johnson forklift mounts.

- Use the provided #6 mounting hardware to attach the bracket to the printer. Note the positions of the #6 screws, as they vary in length.
- Proceed to attach the printer mount assembly to the chosen GJ forklift mount using the #10-32 nyock nuts found in hardware bag 7120-0722.

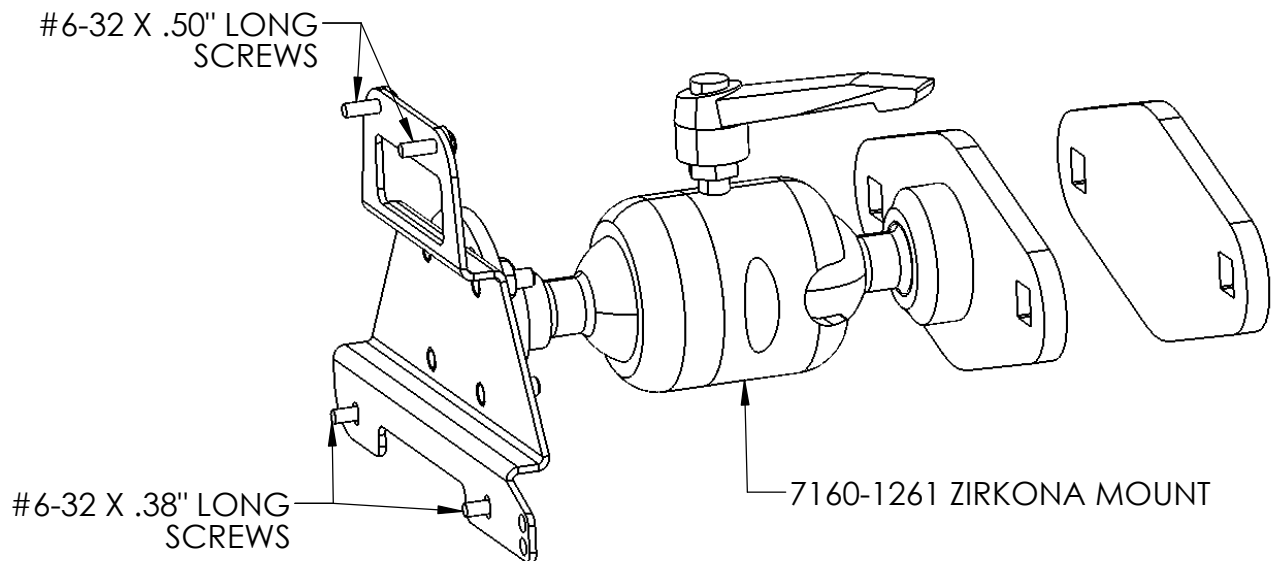
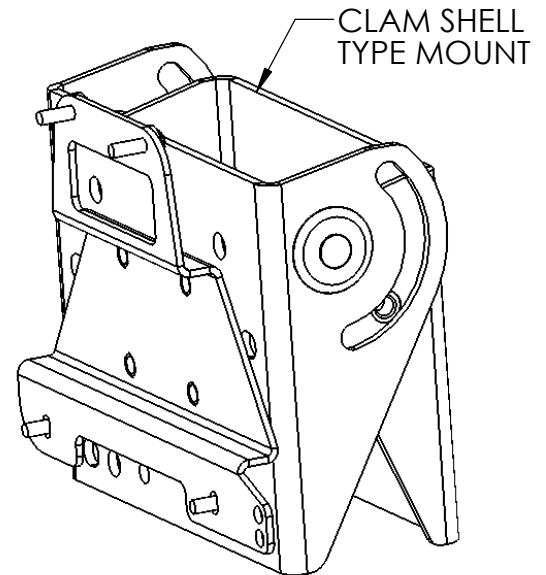

**Product Mounting Disclaimer**

Gamber-Johnson is not liable under any theory of contract or tort law for any loss, damage, personal injury, special, incidental or consequential damages for personal injury or other damage of any nature arising directly or indirectly as a result of the improper installation or use of its products in vehicle or any other application. In order to safely install and use Gamber-Johnson products full consideration of vehicle occupants, vehicle systems (i.e., the location of fuel lines, brakes lines, electrical, drive train or other systems), air-bags and other safety equipment is required. Gamber-Johnson specifically disclaims any responsibility for the improper use or installation of its products not consistent with the original vehicle manufactures specifications and recommendations, Gamber-Johnson product instruction sheets, or workmanship standards as endorsed through the Gamber-Johnson Certified Installer Program.