



INSTALLATION INSTRUCTIONS

<u>Product</u>	<u>Revision</u>	<u>Form</u>
7160-0817 PRINTER MOUNT, ZEBRA QLN420	REV. B	INST-713
Printing Spec:		

The Zebra QLN420 printer bracket is designed to be mounted to various Gamber-Johnson forklift mounts.

- Use the provided #6 mounting hardware to attach the bracket to the printer. Note the positions of the #6 screws, as they vary in length.
- Proceed to attach the printer mount assembly to the chosen GJ forklift mount using the #10-32 nyock nuts found in hardware bag 7120-0722.

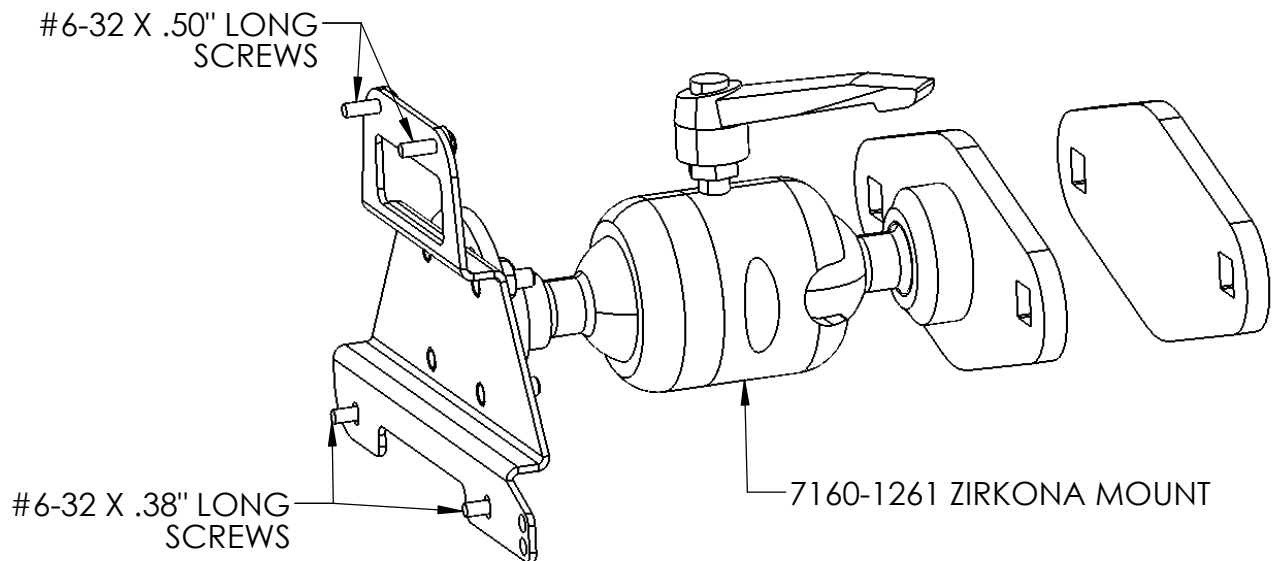
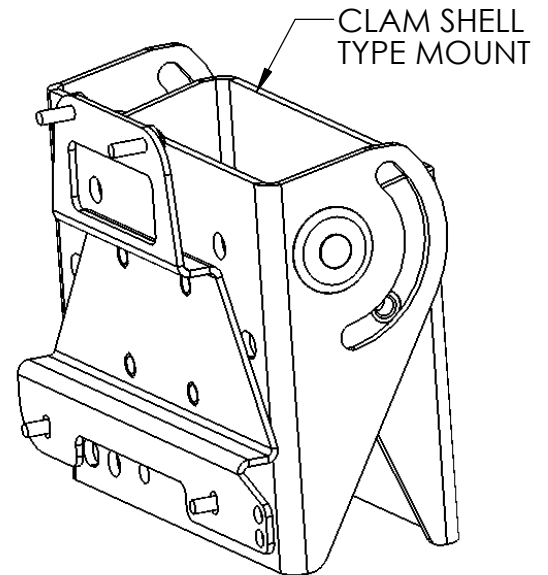

Product Mounting Disclaimer

Gamber-Johnson is not liable under any theory of contract or tort law for any loss, damage, personal injury, special, incidental or consequential damages for personal injury or other damage of any nature arising directly or indirectly as a result of the improper installation or use of its products in vehicle or any other application. In order to safely install and use Gamber-Johnson products full consideration of vehicle occupants, vehicle systems (i.e., the location of fuel lines, brakes lines, electrical, drive train or other systems), air-bags and other safety equipment is required. Gamber-Johnson specifically disclaims any responsibility for the improper use or installation of its products not consistent with the original vehicle manufactures specifications and recommendations, Gamber-Johnson product instruction sheets, or workmanship standards as endorsed through the Gamber-Johnson Certified Installer Program.



INSTALLATION INSTRUCTIONS

<u>Product</u> 7160-2008 4" FANFOLD LABEL HOLDER	<u>Revision</u> Rev A	<u>Form</u> INST-1202 Printing Spec: PS-001
---	---------------------------------	---

This instruction sheet is for mounting the 4" fanfold label holder. This mount is designed to work in conjunction with the Gamber-Johnson QLN420/ZQ630 printer mount (7160-0817). For setup of the Zebra QLN420 or ZQ630 printers, reference the Zebra product manuals for the specific products. To run fanfold labels in a QLN420 or ZQ630 printer, you will need a Zebra variable width spacer kit (Zebra PN: P1050667-061).

Attaching the printer to the label holder:

1. Attach the printer to the printer bracket (7160-0817 - sold separately) with the #6 machine screws and flat washers found in hardware bag 7120-0722. The 1/2" long screws attach in the (2) holes closest to the front of the printer.
2. Attach the printer with the bracket attached to the label box with the (4) #10 nylock nuts provided in hardware bag 7120-0722.
3. Cover the ends of the studs with the (4) #10 plastic cap nuts found in hardware bag 7120-1227. This will help prevent the labels from getting caught on the ends of the studs when feeding.

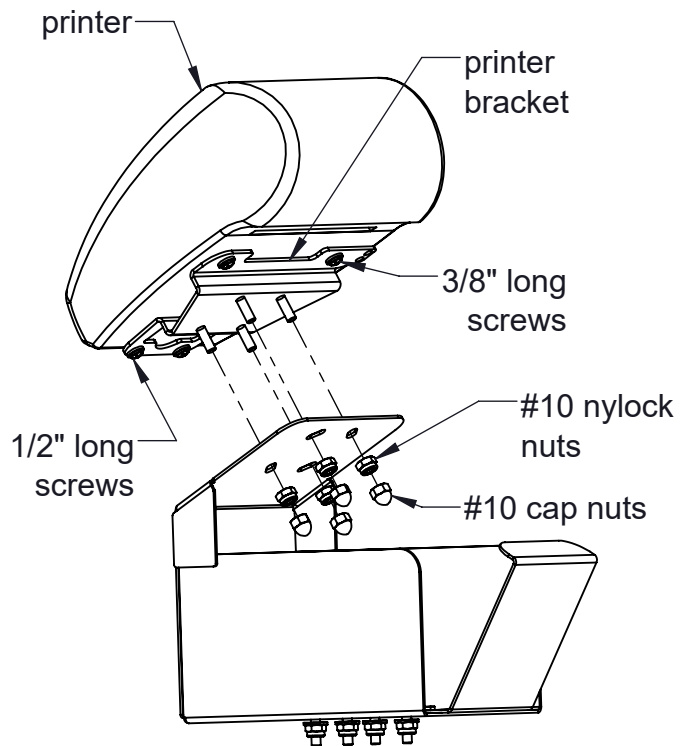

Product Mounting Disclaimer

Gamber-Johnson is not liable under any theory of contract or tort law for any loss, damage, personal injury, special, incidental or consequential damages for personal injury or other damage of any nature arising directly or indirectly as a result of the improper installation or use of its products in vehicle or any other application. In order to safely install and use Gamber-Johnson products full consideration of vehicle occupants, vehicle systems (i.e., the location of fuel lines, brake lines, electrical, drive train or other systems), air-bags and other safety equipment is required. Gamber-Johnson specifically disclaims any responsibility for the improper use or installation of its products not consistent with original vehicle manufactures specifications and recommendations, Gamber-Johnson product instruction sheets, or workmanship standards as endorsed through the Gamber-Johnson Certified Installer Program.

© Copyright 2024 Gamber-Johnson, LLC

If you need assistance or have questions, call Gamber-Johnson at 1-800-456-6868



Attaching the label holder to a vehicle mount:

1. Attach the 4" fanfold label holder to the vehicle mount by inserting the (4) studs on the AMP's anchor plate through the slots in the label stop and the label box.
2. Loosely attach the mount to the motion attachment on the vehicle mount with the #10 flat washers and nylock nuts provided in hardware bag 7120-1227.
3. Adjust the label stop for the length of fanfold labels (6" or 8") being used in the mount and tighten #10 nylock nuts in place.

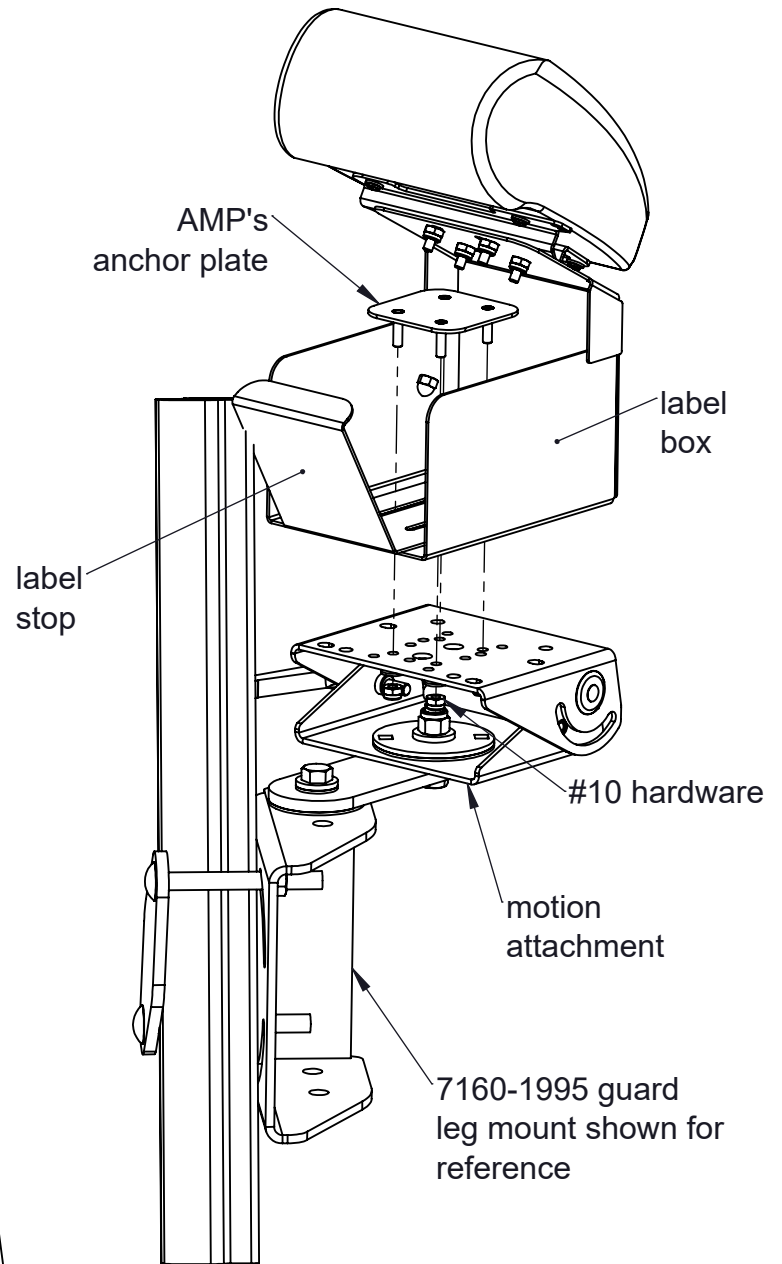
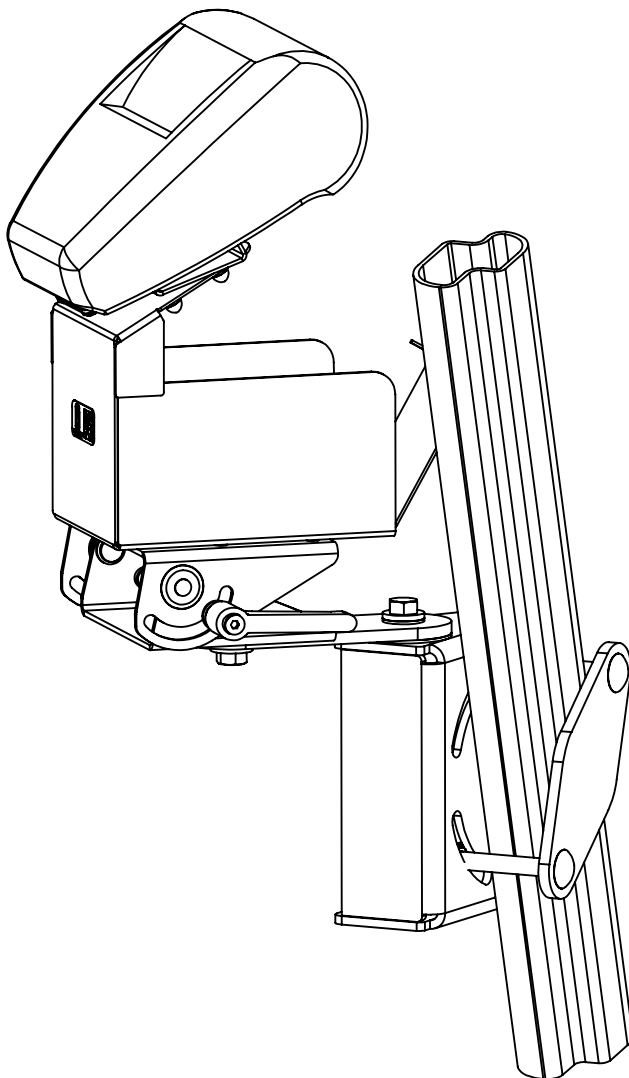



label opening on bottom side of printer



Zebra variable width spacer kit
(Zebra PN: P1050667-061)



4" wide fanfold labels fed through the opening on bottom



internal view of 4" wide fanfold labels being fed through the spacer kit