

INSTALLATION INSTRUCTIONS

Product

7160-0509

LEG KIT - GM TRUCK - 2014+

Revision

Rev.B

Form

INST-608

Printing Spec: PS-001

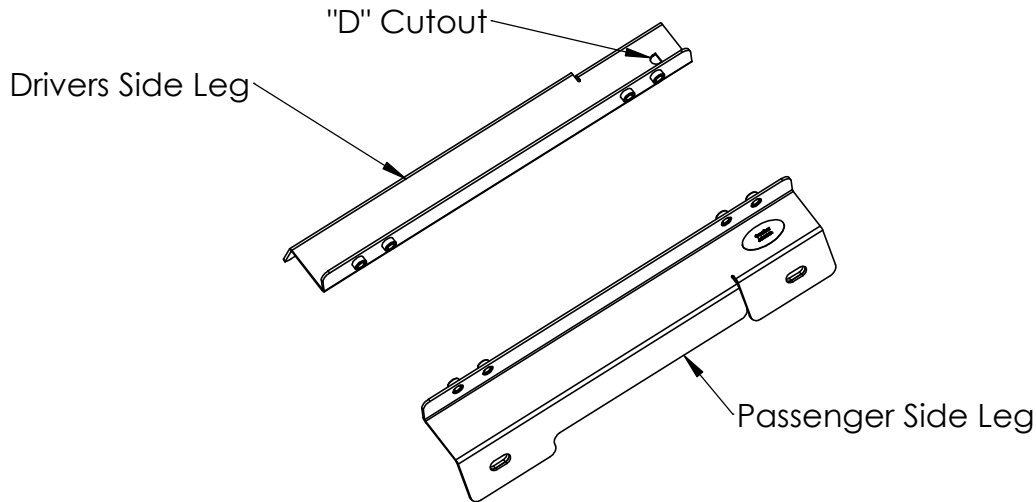

1. Remove the front passenger seat.
2. Disconnect the USB and Cable harness under the carpeting located under the front passenger seat.
3. Remove the center seat/console by removing the 4 caps, then removing the 4 bolts (2 each side) with a 15MM socket.

View with passenger seat and center seat removed.



Product Mounting Disclaimer

Gamber-Johnson is not liable under any theory of contract or tort law for any loss, damage, personal injury, special, incidental or consequential damages for personal injury or other damage of any nature arising directly or indirectly as a result of the improper installation or use of its products in vehicle or any other application. In order to safely install and use Gamber-Johnson products full consideration of vehicle occupants, vehicle systems (i.e., the location of fuel lines, brakes lines, electrical, drive train or other systems), air-bags and other safety equipment is required. Gamber-Johnson specifically disclaims any responsibility for the improper use or installation of its products not consistent with the original vehicle manufactures specifications and recommendations, Gamber-Johnson product instruction sheets, or workmanship standards as endorsed through the Gamber-Johnson Certified Installer Program.

© Copyright 2013 Gamber-Johnson, LLC



4. Attach the drivers side and passenger side legs to the transmission hump in the same location that the center seat/console was located. Use the existing bolts that were removed earlier. The drivers side leg has a "D" cutout to identify it.



5. Attach Top Plate using 3/8- 16 x .75 bolts and washers supplied in hardware bag.



6. View with equipment installed on top plate and passenger seat reinstalled.