



Very Well Connected™

# INSTALLATION INSTRUCTIONS

<b><u>Product</u></b> <b>7160-0230 POLE BRACE-SHORT</b> <b>7160-0231 POLE BRACE-LONG</b>	<b><u>Revision</u></b> Rev.B	<b><u>Form</u></b> INST-460 <b>Printing Spec: PS-001</b>
--	---------------------------------	--

7160-0230 Pole Brace-Short is for installations where a brace length in a range from 10.25" up to 16.25" is needed.

7160-0231 Pole Brace Long can accommodate installations requiring a brace from 10.25" up to 35.25" inches

\*\*Lengths less than 29.25" require cutting.

## Assembly

Slide the Brace Clamp onto the Outer tube.  
DO NOT tighten at this time. Slide the inner tube into the outer tube.

Slide the Pole Clamp over the pedestal base tube, paying attention which side will be most suitable for attaching the brace. Insert the bolt provided through the hole in the flat end of the inner tube. Insert the bolt through the clearance hole in the Pole Clamp and tighten to 15 in/lbs. Attach the other end of the brace to the vehicle using customer supplied hardware.

The flat ends of the brace may be bent to fit your installation.

When positioning the short brace, do not exceed a length of 16.25". It is recommended that the short brace tubes have 1" of overlap, and so you cannot exceed 16.25" with the short brace.

When fitting a Long Brace, it may be necessary to cut the inner tube to a length suitable for your installation. It is recommended on installations requiring the long brace that the inner tube have 2" minimum of insertion into the outer tube and may have a maximum of approximately 6".

With vehicle end of the brace located. "Preload" the brace by pushing the top of the pedestal tube in a direction to extend the brace slightly (1/16 1/8 inch), then tighten the Brace Clamp bolt to 15 IN/LBS.

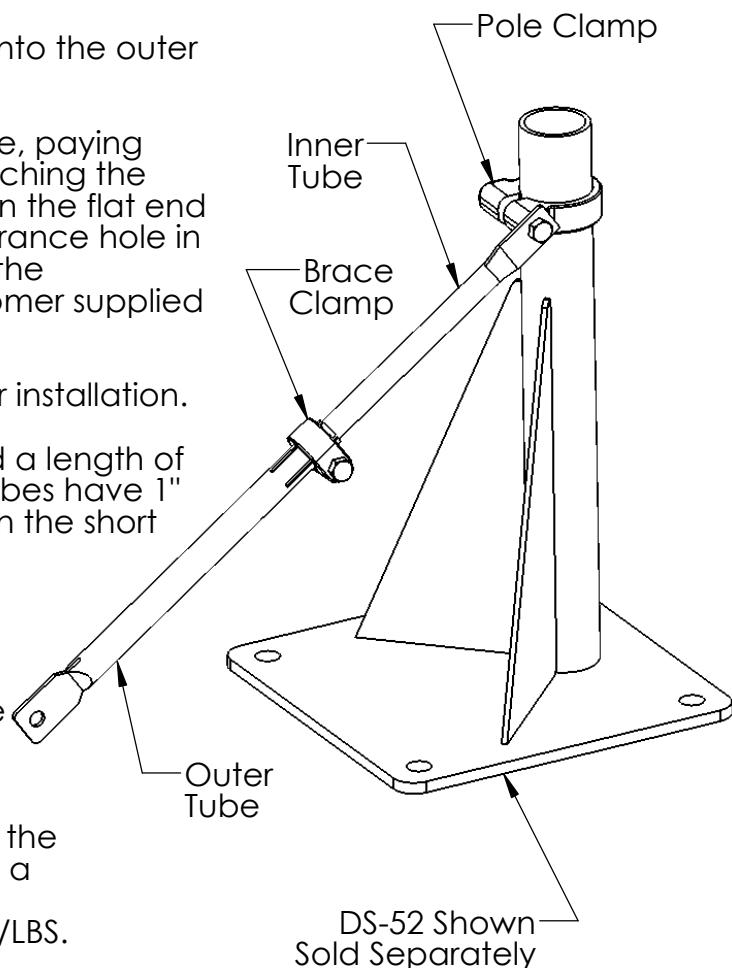

### Product Mounting Disclaimer

Gamber-Johnson is not liable under any theory of contract or tort law for any loss, damage, personal injury, special, incidental or consequential damages for personal injury or other damage of any nature arising directly or indirectly as a result of the improper installation or use of its products in vehicle or any other application. In order to safely install and use Gamber-Johnson products full consideration of vehicle occupants, vehicle systems (i.e., the location of fuel lines, brakes lines, electrical, drive train or other systems), air-bags and other safety equipment is required. Gamber-Johnson specifically disclaims any responsibility for the improper use or installation of its products not consistent with the original vehicle manufactures specifications and recommendations, Gamber-Johnson product instruction sheets, or workmanship standards as endorsed through the Gamber-Johnson Certified Installer Program.

© Copyright 2013 Gamber-Johnson, LLC

If you need assistance or have questions, call Gamber-Johnson at 1-800-456-6868