

INSTALLATION INSTRUCTIONS

Product

7160-0160 VEHICLE LEG KIT

Revision

Rev.B

Form

INST-413

CHEVROLET/GMC 1500/2500/3500 C/K (2007+ NEW BODY STYLE)
CHEVROLET/GMC 1500/2500/3500 C/K (1999-2006 & 2007 CLASSIC BODY STYLE)
CHEVROLET AVALANCHE (2002-2006, 2007+)
CHEVROLET SILVERADO (2007+ NEW BODY STYLE)
CHEVROLET SILVERADO (1999-2006 & 2007 CLASSIC BODY STYLE)
CHEVROLET SUBURBAN (2000-2006, 2007+)
CHEVROLET TAHOE (2000-2006, 2007+)
GMC SIERRA (2007+ NEW BODY STYLE)
GMC SIERRA (2000-2006 & 2007 CLASSIC BODY STYLE)
GMC YUKON/YUKON XL (2000-2006, 2007+)

Printing Spec: PS-001

The 7160-0160 is a no holes bored base for the vehicles listed above. The base mounts under the driver and passenger bucket seats and is compressed to the floor using the seat bolts.

Assembling the 7160-0160:

1. Bolt the front legs and the front stabilizer bracket to the top plate in the approximate location they will be in, with the 3/8-16unc x 3/4" long bolts, and lock washers that were provided in the hardware bag. (See figure. I.)
2. Bolt the rear stanchion to the top plate using the 1/4-20unc x 3/4" flat head machine screw that is provided in the hardware bag. (See Figure I.)

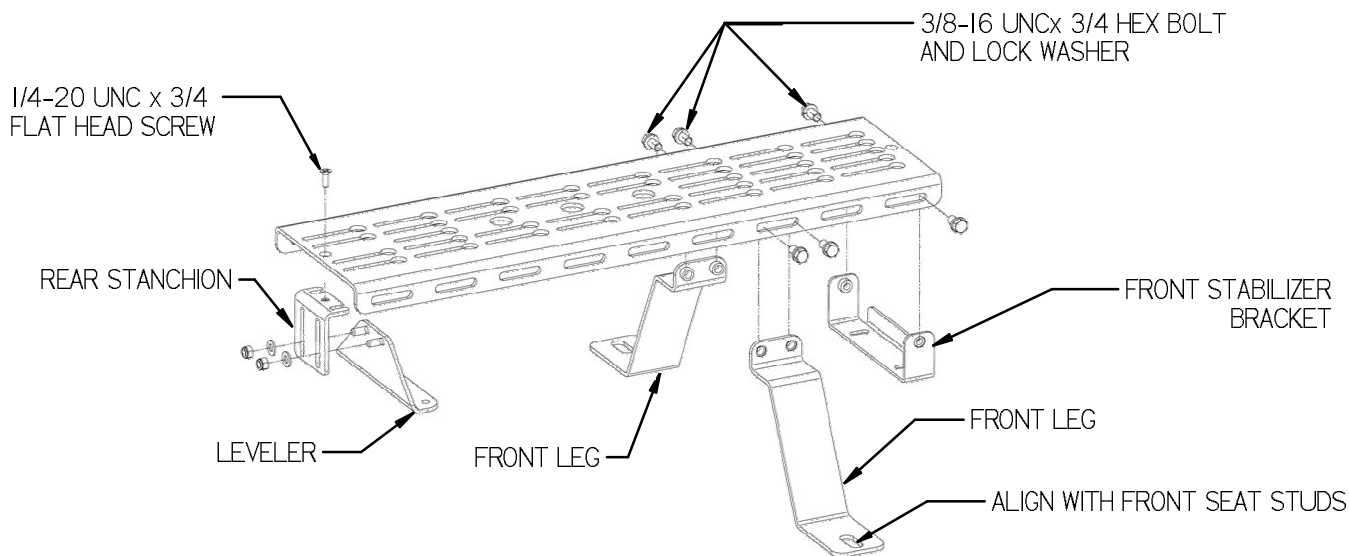

Figure I Assembly of Leg Kit 7160-0160

Product Mounting Disclaimer

Gamber-Johnson is not liable under any theory of contract or tort law for any loss, damage, personal injury, special, incidental or consequential damages for personal injury or other damage of any nature arising directly or indirectly as a result of the improper installation or use of its products in vehicle or any other application. In order to safely install and use Gamber-Johnson products full consideration of vehicle occupants, vehicle systems (i.e., the location of fuel lines, brakes lines, electrical, drive train or other systems), air-bags and other safety equipment is required. Gamber-Johnson specifically disclaims any responsibility for the improper use or installation of its products not consistent with the original vehicle manufactures specifications and recommendations, Gamber-Johnson product instruction sheets, or workmanship standards as endorsed through the Gamber-Johnson Certified Installer Program.

© copyright 2012 Gamber-Johnson, LLC

Mounting the 7160-0160:

1. Unbolt the front bucket seats and lift them off the seat studs; then remove the center console or the smaller interior seat.
2. Place the assembled leg kit over the transmission hump so the front seat studs come up through the slots in the front legs.
3. Reposition the bucket seats and bolt back into place.
4. Adjust the leveler to tighten if needed.