

INSTALLATION INSTRUCTIONS

Product

12" Ergonomic Console Box & Accessories
MCS-ERGOBOX12

Revision

Rev D

Form

INST-284

The purpose of this instruction sheet is to illustrate the manufacturer's recommended method for installing the MCS-ERGOBOX12. MCS-ERGOBOX12 is a discrete solution for mounting various mobile communication control heads. Included with the MCS-ERGOBOX12 is one set of short Faceplate Vertical Offsets. Due to a shallow depth in the front end of the console box, these Faceplate Vertical Offsets must be used in place of the Vertical Offsets that come with Gamber-Johnson Faceplate Kits (see INST-3).

1. When installing the MCS-ERGOBOX12 onto a Gamber-Johnson MCS Top Plate, insert and loosely assemble four 1/4-20 carriage bolts, four 1/4" Dia. washers, four 1/4" lock washers and four 1/4-20 hex nuts about the desired mounting slots in the bottom of the box (see **FIG. 1**). Orient the head of the carriage bolts below the box.

2. Insert the four heads of the carriage bolts into the desired corresponding key holes (see **FIG. 1**) on the MCS-Top Plate until the bolt heads drop below the Top Plate. If the chosen mounting slots do not line up with the key holes on the Top Plate it will be necessary to assemble the hardware about the box and the Top Plate at the same time. Place box in desired position and tighten hardware.

3. Due to the shallow depth of the face nearest the vehicle occupants (see **FIG. 3**), as compared to the MCS-Epic console box series, it is necessary to replace the standard Vertical Offsets with a set of shorter Vertical Offsets (1 set is included with the MCS-ERGOBOX12). The radio/radio head in the lowest position on the box will require the Short Vertical Offset. Follow instruction sheet INST-3 for assembly and installation instructions, substituting the short Faceplate Vertical Offsets (see **FIG. 2**) with the Vertical Offsets that come with Gamber-Johnson Faceplate Kits.

Accessories

The MCS-ERGOBOX12 has many accessories that are designed to attach to the exterior of the box. The next few sections of this instruction sheet are dedicated to illustrating how to attach the various accessories.

Cup Holder (MCS-CUP2)

1. The cup holder is designed to mount to either the short, front face of the MCS-ERGOBOX12 or directly to an MCS Top Plate. There are two 10-32 x .375 Phillips Pan Head screws included to attach the cup holder to the box (see **FIG. 3**)

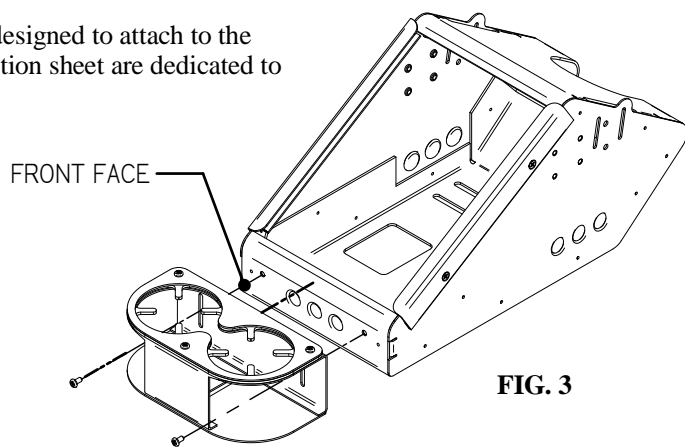
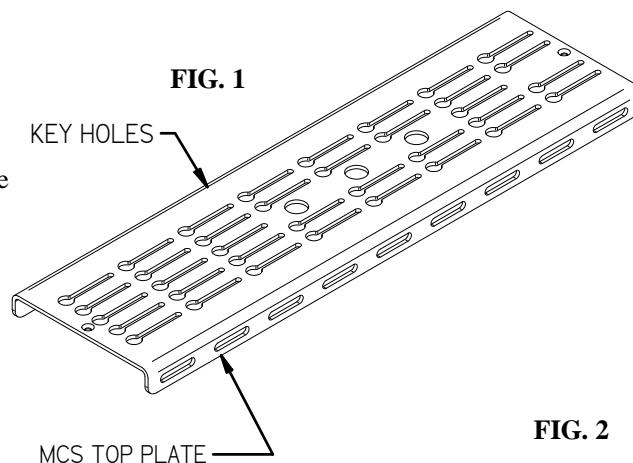
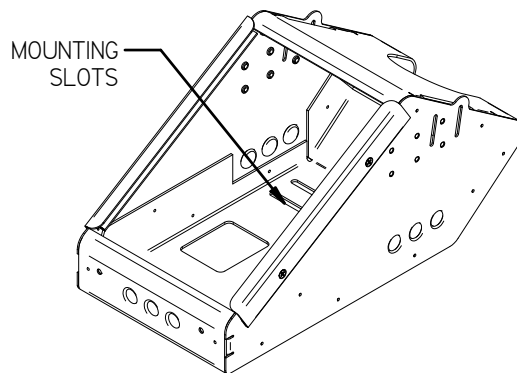

Product Mounting Disclaimer

Gamber-Johnson is not liable under any theory of contract or tort law for any loss, damage, personal injury, special, incidental or consequential damages for personal injury or other damage of any nature arising directly or indirectly as a result of the improper installation or use of its products in vehicle or any other application. In order to safely install and use Gamber-Johnson products full consideration of vehicle occupants, vehicle systems (i.e., the location of fuel lines, brakes lines, electrical, drive train or other systems), air-bags and other safety equipment is required. Gamber-Johnson specifically disclaims any responsibility for the improper use or installation of its products not consistent with the original vehicle manufacturers specifications and recommendations, Gamber-Johnson product instruction sheets, or workmanship standards as endorsed through the Gamber-Johnson Certified Installer Program.

© copyright 2012 Gamber-Johnson, LLC

If you need assistance or have questions, call Gamber-Johnson at 1-800-456-6868

Communications Bracket (MCS-COMBRKT)

1. The communications bracket is designed to have any Gamber Johnson Clevis device mounted to it. In order to mount a Clevis/Docking Station, or Computer Cradle, assembly to the MCS-COMBRKT, the MCS-ERGOBOX12 must be pulled away from the dash. Assemble the MCS-COMBRKT, desired Clevis Device, and MCS-ERGOBOX12 prior to attaching the box to the Top Plate (see FIG. 4).

2. Adjust the assembly to the desired position. Attach to Top Plate by assembling four 1/4-20 carriage bolts, four 1/4" DIA. flat washers, four 1/4" lock washers and four 1/4-20 hex nuts about the bottom of the box and the Top Plate.

NOTE: The pattern of mounting holes for the MCS-COMBRKT is known as an AMPS pattern.

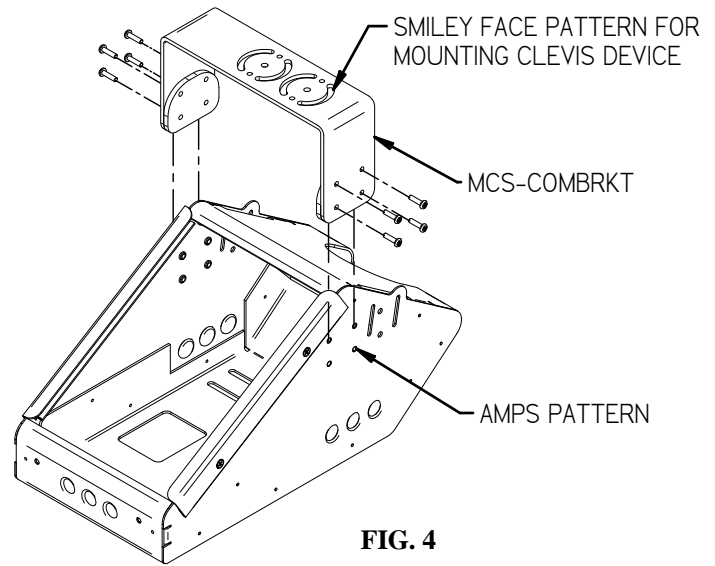

FIG. 4

Mounting to the In-Dash Bracket

1. If mounting the MCS-VERTBOX12 in a Ford Crown Victoria, the box can also attach to the In-Dash Bracket for further stability, using NP-DASH-KT (see FIG. 5).

2. After the In-Dash Bracket is attached to the vehicle, align the MCS-ERGOBOX12 and fasten to the In-Dash Bracket using two braces, four 1/4-20 x .50" Socket Button Head screws, four 10-32 x .50" Socket Head Cap Screws and four #10 flat washers all found in NP-DASH-KT. Assemble as illustrated in FIG. 5.

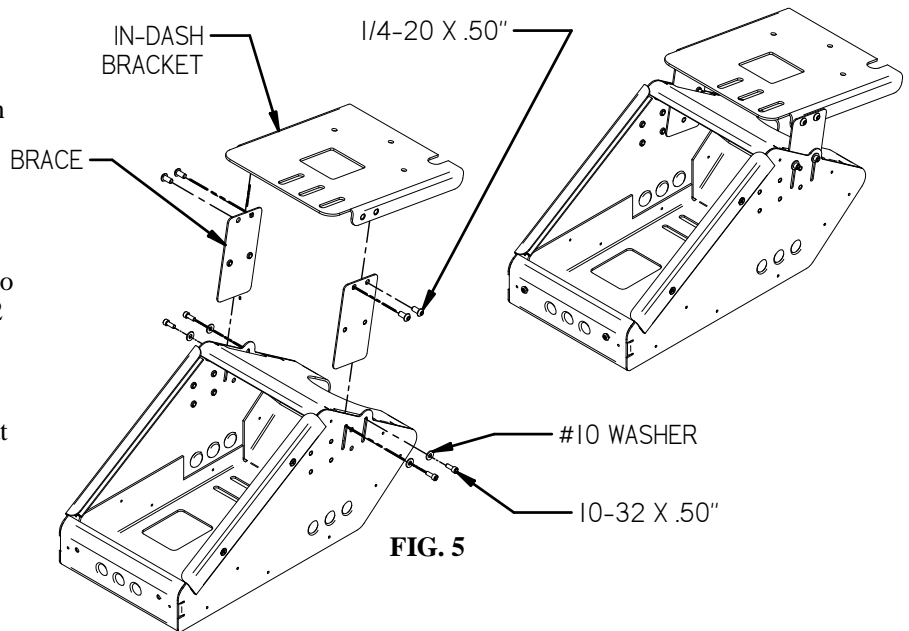

FIG. 5

Assembling the MCS-MICPLT

1. The MCS-MICPLT is a kit that allows a radio microphone to be mounted in the same fashion as all Gamber Johnson Faceplates. The mic clip itself is not provided with the MCS-MICPLT kit as it is standard that a mic clip is shipped with most communication devices that use a microphone. Assemble as illustrated in FIG. 6.

2. It is recommended that if using the MCS-MICPLT kit to place the finished assembly in the lowest position on the MCS-ERGOBOX12. By assembling the kit in this fashion you be able to avoid using the short Faceplate Vertical Offset (see FIG. 2).

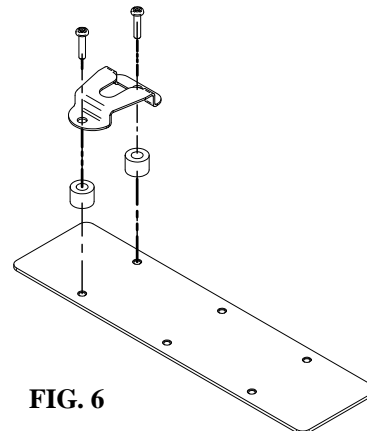
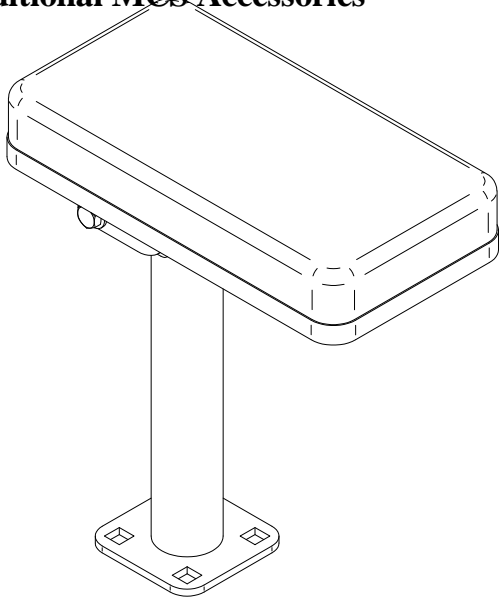
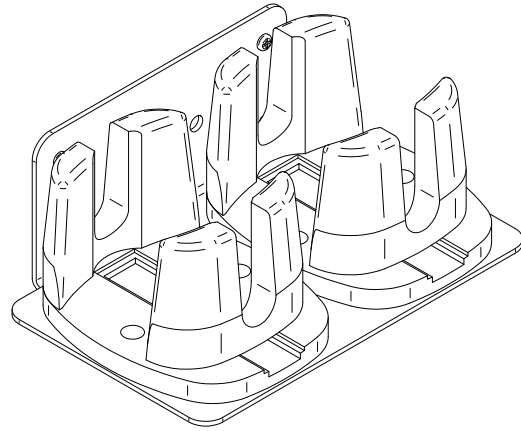

FIG. 6

Additional MCS Accessories



MCS-ARMREST



MCS-CUP2

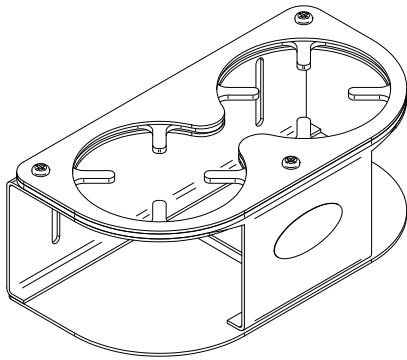

MCS-CUPHOLD2

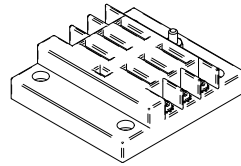

**7160-0110
(6 Circuit Power Strip)**

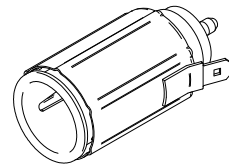

**7160-0063
(Cigarette Lighter Adapter Kit)**

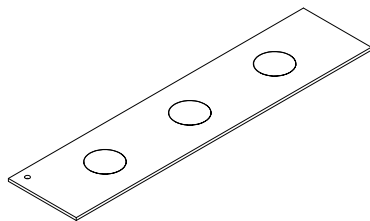

**3130-0361
(Knockout Filler Panel)**

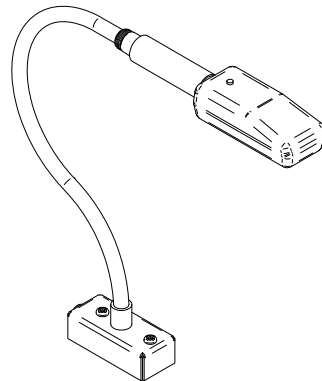

**7160-0100
(LED Light Assembly)**

INSTALLATION INSTRUCTIONS

Product
Faceplates

Date
02/23/01

Form #
INST3

ASSEMBLING MCS FACEPLATES: (Refer to figure 1)

1. Check that the following pieces are present:
 - Dual lock fastener (supplied w/console box)
 - (1) faceplate vertical offset
 - (1) faceplate top bracket
 - (1) flat washer #6
 - (1) 6-32 nut
2. For each faceplate, slide the faceplate vertical offset (item 1) on the stud in faceplate top bracket (item 2). Add flat washer (item 3) and hex nut (item 4). Remove the extra strips of dual lock fastener pressed onto each console box under holddown rails, cut to same length as each faceplate, remove protective film covering the adhesive strip and apply to top bracket as shown.
3. If the faceplates are being mounted in an older style MCS Console Box (those with threaded inserts on the top surface of the side panels/holddown screws passing through slots in existing face plates or blank panels), DO NOT attach the strip of dual lock fastener on each faceplate as described above. When installing faceplates into these MCS Console Boxes, mark any that cover the threaded inserts and drill a .312 diameter clearance hole as shown in Figure 1.

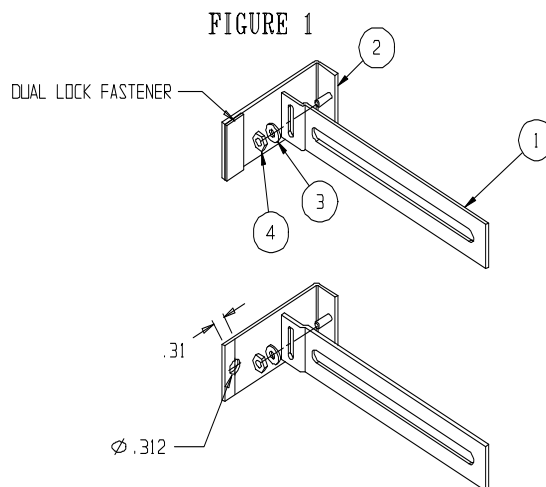

ASSEMBLING MCS FACEPLATES TO CONTROL HEADS AND INSTALLING IN MCS CONSOLE BOXES (Refer to figures 2 & 3).

1. Install the faceplates on each control head as shown in figure 2. Adjust the faceplates so the mounting holes in the sides of the control head line up in the slots of the faceplate vertical offsets and so the desired amount of the control head will extend from the console. Make sure to allow enough room underneath for any connectors that may be required. Test the fit of each control head, the tallest heads may need to be installed near the higher end of the console.
2. Arrange the control heads in the console box as desired. Blank panels of various sizes have been provided to act as spacers between each control head, if needed. Secure in place by attaching a piece of dual lock fastener to each end of the blank panel and then pressing the strips of dual lock fastener on the faceplates, blank panels and console box together.
3. Attach the MCS Console Box holddowns to the sides of the console box and over faceplates with (6) 10-32 x .38 Phillips head machine screws.

