



# INSTALLATION INSTRUCTIONS

**Product**

7160-1905

LEG KIT - CHEVY SILVERADO EV 2024+

**Revision**

Rev A

**Form**

INST-1168

Printing Spec: PS-001

1. Remove the front seats and center console from the vehicle. Below are some pictures of some of the hardware that needs to be removed.

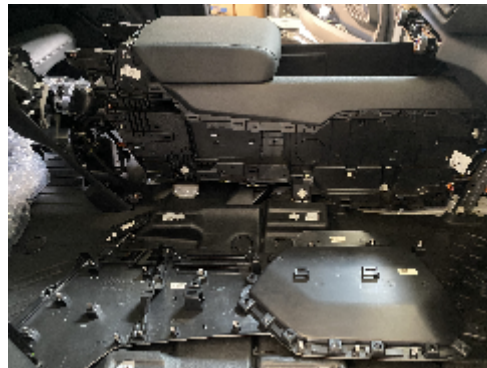

**Product Mounting Disclaimer**

Gamber-Johnson is not liable under any theory of contract or tort law for any loss, damage, personal injury, special, incidental or consequential damages for personal injury or other damage of any nature arising directly or indirectly as a result of the improper installation or use of its products in vehicle or any other application. In order to safely install and use Gamber-Johnson products full consideration of vehicle occupants, vehicle systems (i.e., the location of fuel lines, brake lines, electrical, drive train or other systems), air-bags and other safety equipment is required. Gamber-Johnson specifically disclaims any responsibility for the improper use or installation of its products not consistent with original vehicle manufactures specifications and recommendations, Gamber-Johnson product instruction sheets, or workmanship standards as endorsed through the Gamber-Johnson Certified Installer Program.

© Copyright 2024 Gamber-Johnson, LLC

If you need assistance or have questions, call Gamber-Johnson at 1-800-456-6868

2. Once the center console is loose from the vehicle, disconnect the wire harnesses and remove the console from the vehicle.
3. Remove the square AC module from the back of the console box.
4. Remove the transponder programmer from the bottom of the cupholder
5. Remove the transponder detector from the center console
6. Remove the cig power port from the center console
7. Remove the Dual USB-C ports from the center console. you will need to drill out the 4 plastic rivets to remove the mounting plate so it can be relocated.



8. Attach the transponder programmer to the black plastic window with (2) #10 machine screws, flat washers, and lock nuts found in the hardware bag.
9. Attach the transponder detector to the black plastic window with (2) #10 machine screws and the sheet metal bracket found in the hardware bag.
10. Attache the black plastic window to the front closure panel with the (4) #10 flat washers and lock nuts found in the hardware bag.
10. Snap in the square AC power module that was removed from the factory center console, into the front side of the closure panel.
11. Attach the Dual USB-C module to the back side of the closure panel with (4) #10 flat washers and lock nuts found in the hardware bag.
12. Attach the cig power adapter that was removed from the factory center console into the opening on the front closure panel.
13. Attach all the coresponding wire harnesses for the components relocated to the front closure panel.

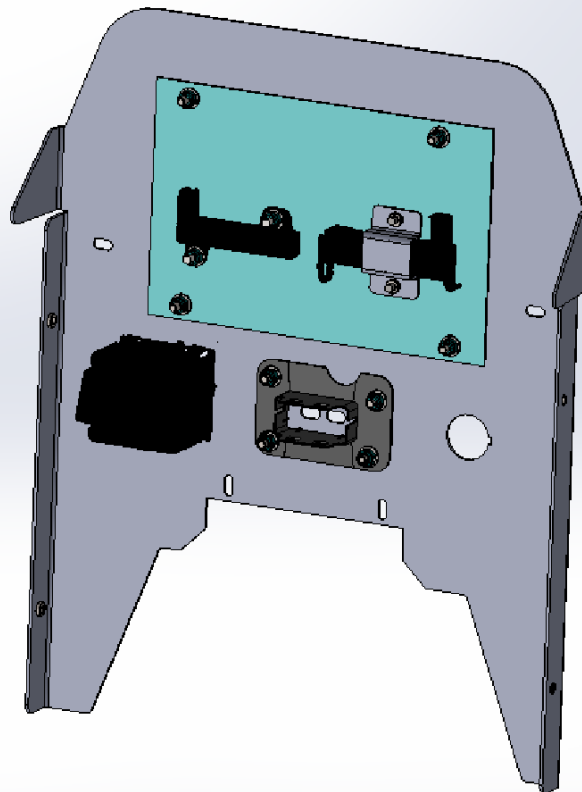



14. Tuck the wire harnesses up under the dash behind the front closure panel and attach the front panel to the dash with the 2 front screws that held the factory center console in place.
15. Attach the front driver and passenger side closure panels to the front closure panel with (2) #10 x 1/2" long machine screws and flat washers provided in the hardware bag.
16. Attach the back side of the side panels to the dash with the screws (1 each side) that were removed when the factory center console was removed.
17. Attach the transmission cover to the front closure panel by inserting the top flange under the cutout at the bottom of the front closure panel and rotating the transmission cover downward to get the flange behind the front closure panel. Attach with (2) #10-x 1/2" long machine screws and flat washers found in the hardware bag.

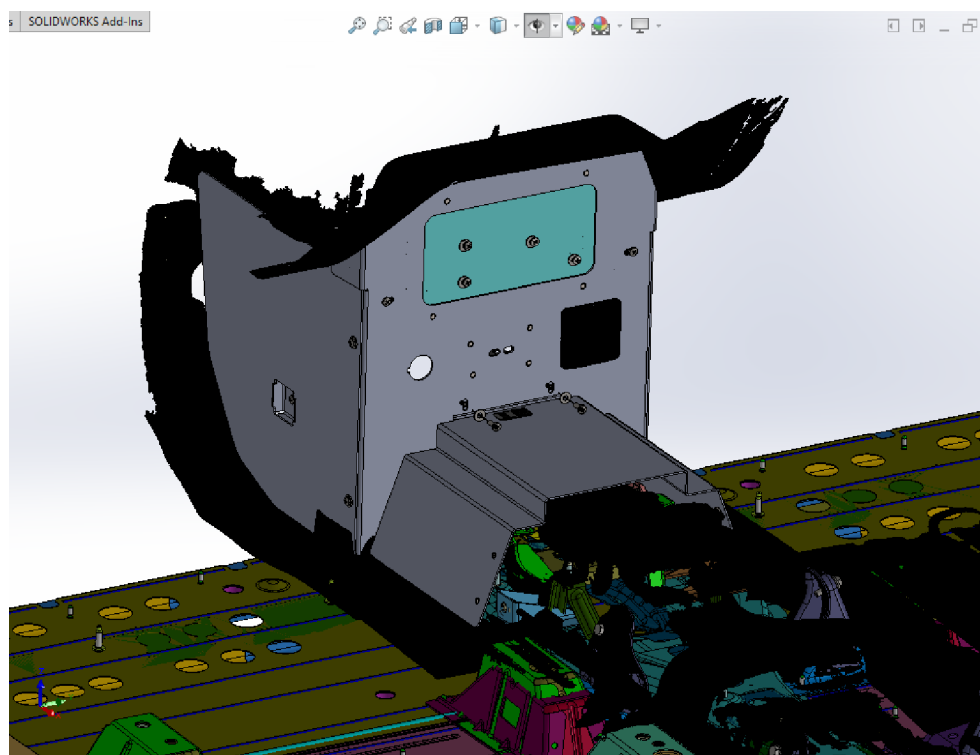
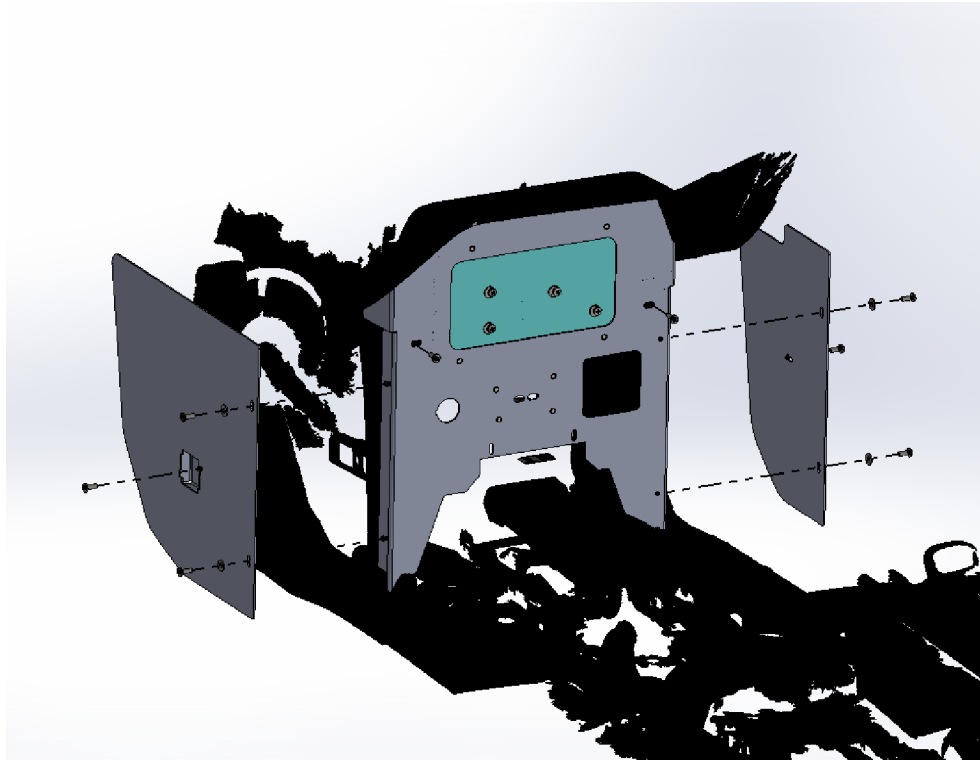

18. loosely attach the driver and passenger side leg brackets with the bolts removed from the factory center console. Do not tighten.
19. Loosely attach the front of the leg brackets to the transmission cover with (4) #10 x 1/2" long machine screws and flat washers.
20. Insert the back closure plate into the back opening of the side legs and loosely attach with (4) #10 x 1/2" long machine screws and flat washers found in the hardware bag.
21. loosely attach the top plate to the driver and passenger side leg brackets with the (4) 3/8" x 3/4" hex bolts and flat washers found in the hardware bag.
22. Tighten all hardware that was loosely attached in previous steps.

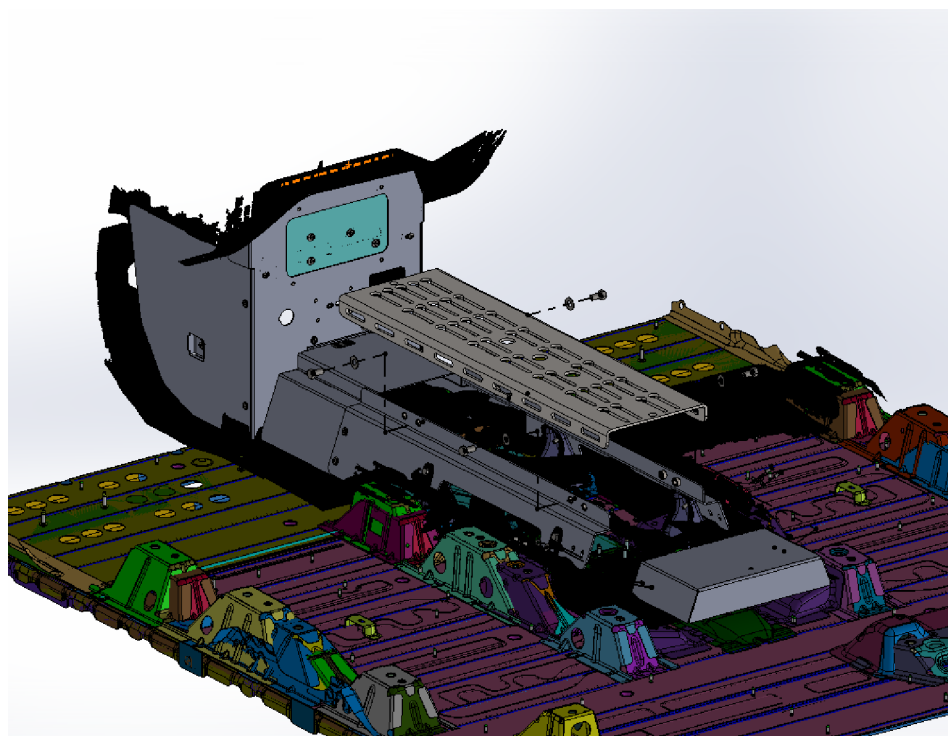
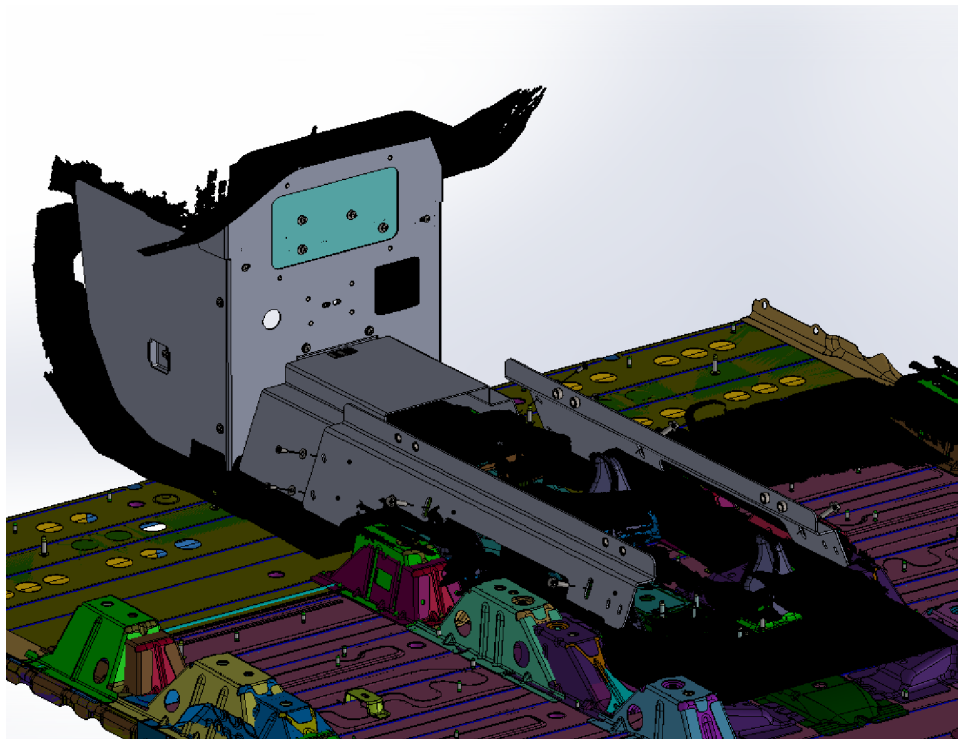

# Completed view when installed

