

# INSTALLATION INSTRUCTIONS

<b><u>Product</u></b> 7170-0514 <b>KIT - INDEPENDENT TABLET DISPLAY</b>	<b><u>Revision</u></b> Rev.B	<b><u>Form</u></b> INST-690 Printing Spec: PS-001
---	---------------------------------	---

Assemble 7170-0514 Kit components as shown below. Refer to the instruction sheet supplied with each component for details specific to the component.

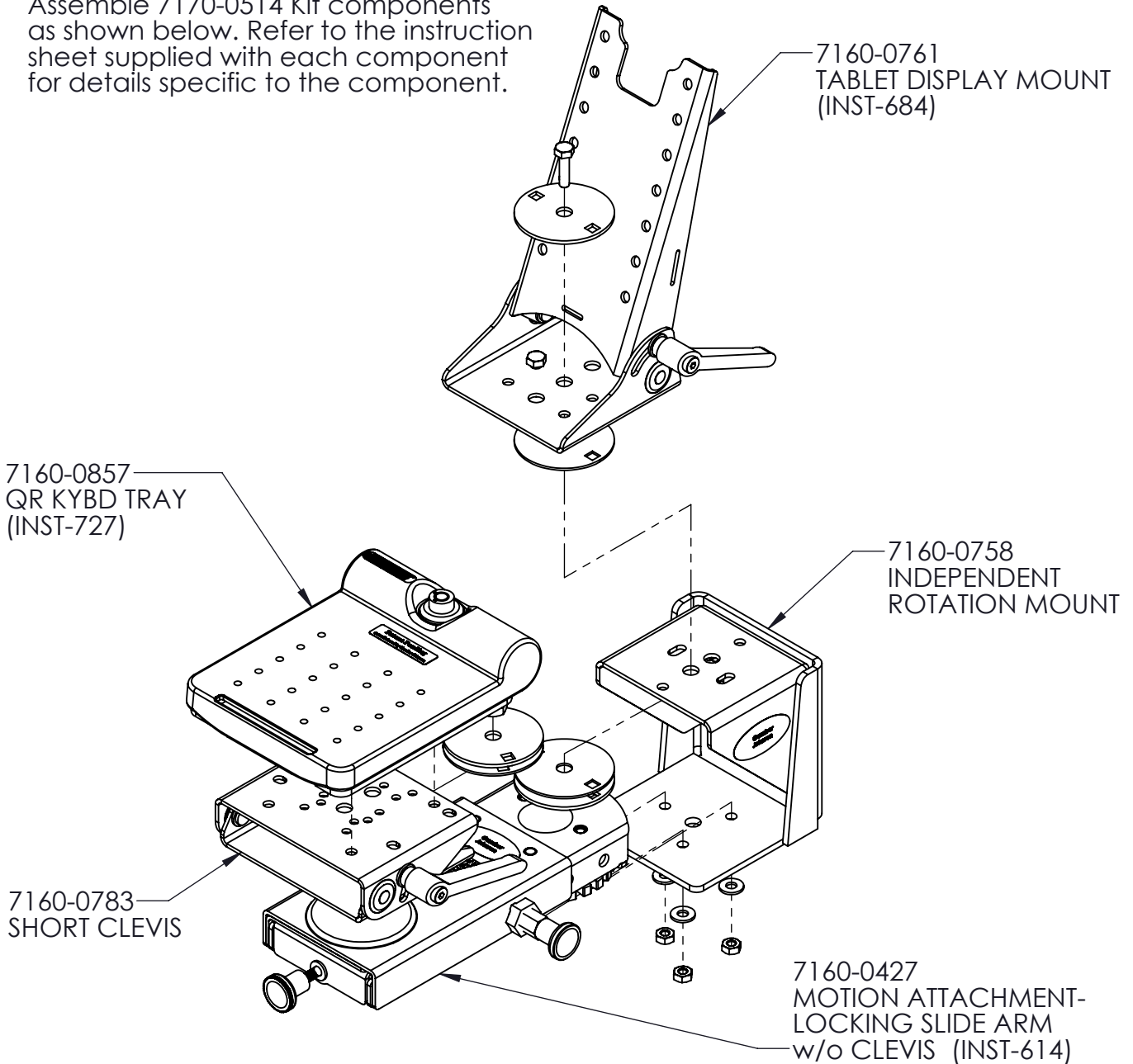

**Product Mounting Disclaimer**

Gamber-Johnson is not liable under any theory of contract or tort law for any loss, damage, personal injury, special, incidental or consequential damages for personal injury or other damage of any nature arising directly or indirectly as a result of the improper installation or use of its products in vehicle or any other application. In order to safely install and use Gamber-Johnson products full consideration of vehicle occupants, vehicle systems (i.e., the location of fuel lines, brakes lines, electrical, drive train or other systems), air-bags and other safety equipment is required. Gamber-Johnson specifically disclaims any responsibility for the improper use or installation of its products not consistent with the original vehicle manufactures specifications and recommendations, Gamber-Johnson product instruction sheets, or workmanship standards as endorsed through the Gamber-Johnson Certified Installer Program.

© copyright 2015 Gamber-Johnson, LLC

If you need assistance or have questions, call Gamber-Johnson at 1-800-456-6868

# INSTALLATION INSTRUCTIONS

## Product

**7160-0857**

**LOW PROFILE QUICK RELEASE KEYBOARD TRAY**

## Revision

Rev.B

## Form

INST-727

**Printing Spec: PS-001**

The 7160-0857 keyboard tray is a keyboard mount that can be used to hold just about any size keyboard. The keyboard tray consists of the VESA75 hole pattern. Attach most keyboards by utilizing the AMPS hole patterns and the provided flat head screws. Strips of adhesive backed Dual Lock are provided in the hardware bag for customers that choose to use the keyboard tray with a keyboard that does not have the AMPS pattern.

## Tools Needed

Phillips head screw driver  
1/2 inch wrench

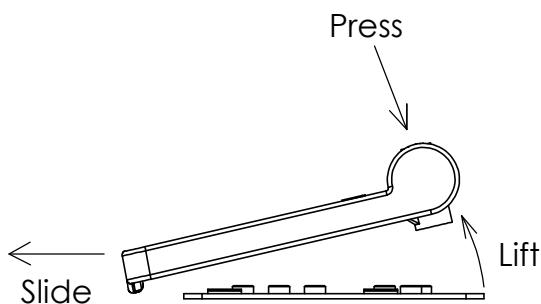
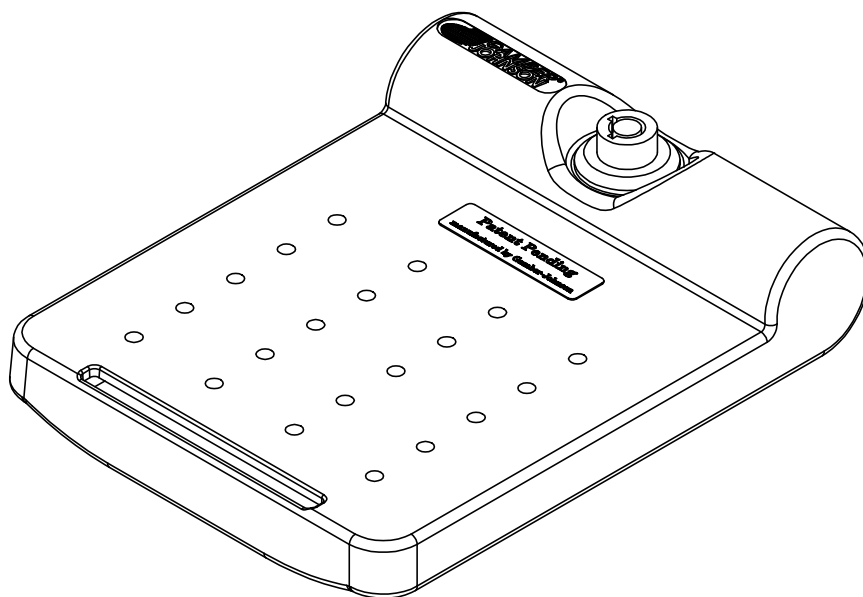

To remove the top quick release plate - press and hold the latch button while lifting slightly and sliding in the shown direction.

### Product Mounting Disclaimer

Gamber-Johnson is not liable under any theory of contract or tort law for any loss, damage, personal injury, special, incidental or consequential damages for personal injury or other damage of any nature arising directly or indirectly as a result of the improper installation or use of its products in vehicle or any other application. In order to safely install and use Gamber-Johnson products full consideration of vehicle occupants, vehicle systems (i.e., the location of fuel lines, brakes lines, electrical, drive train or other systems), air-bags and other safety equipment is required. Gamber-Johnson specifically disclaims any responsibility for the improper use or installation of its products not consistent with the original vehicle manufactures specifications and recommendations, Gamber-Johnson product instruction sheets, or workmanship standards as endorsed through the Gamber-Johnson Certified Installer Program.

© copyright 2017 Gamber-Johnson, LLC

## Mounting the Quick Release Keyboard Tray

Attach the bottom plate of the quick release keyboard tray to a Gamber-Johnson Clevis (Figure 1), using a 1/2 inch wrench and the 1/4" lock washers, and 1/4-20 x .50 hex head screws provided in the hardware bag 7120-0734.

Attach the keyboard to the tray using (4) #8-32 x .50 phillips flat head screws or dual lock adhesive strips.

FIGURE 1: CLEVIS MOUNT

